

TG-5100/B User Guide



General

The Maxtron TG-5100 series of Multi-Format HD-SDI Pattern Generators with audio channel voice ID's are very cost effective, third-generation products. The pattern lineup was specifically chosen to expose system weakness and limitations. For example, a moving zoneplate is used to qualify video compression and scaling. The pathological pattern is used to stress the PLL's in the signal path. There is even the traveling wizard that moves smoothly about the screen to reveal dropped or repeated frames. Then there are the classic patterns: SMPTE RP 219 color bars, 75% full-field color bars, projector alignment and convergence grid, and RGB color fields plus black and white. A user selectable circle overlay is also included to aid in checking for proper display aspect ratios.

Connections

The TG-5100 has all the I/O connections clearly labeled on the top of the unit. Below is the birds-eye view of the TG-5100 Front Panel.

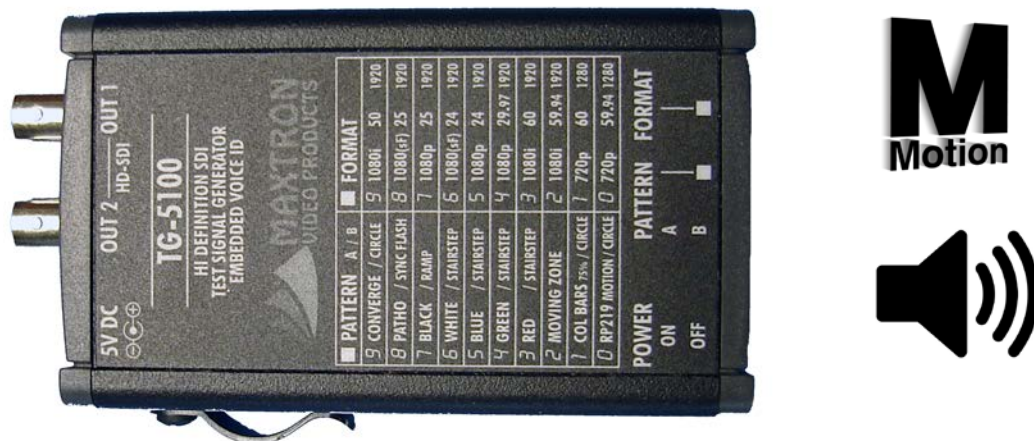

Format:

The top thumbwheel switch selects the format of the HD-SDI output.

Pattern:

The bottom thumb-wheel, along with the A/B pattern modifier toggle switch selects the pattern to be displayed in the format that's selected.

Label:

- *Format:* The numbers to the right of the format position number indicates the standard selected, then the frame rate for progressive patterns or the field rate for the interlaced patterns. Next to the pattern toggle switch is a POWER LED which also indicates whether the selected standard is progressive or interlaced. For progressive standards the light is steady and for interlaced standards the LED has flashes at a rapid but noticeable rate. The final number in the Format column is the number of active horizontal pixels in that format.

- *Pattern:* The pattern column shows the thumbwheel selected pattern as it relates to the pattern modifier A/B switch position. For example, if RP219, pattern 0, is select then the A/B switch turns on/off a circle overlay. If White, pattern 6, is selected then the B (down) position changes the pattern from a flat 75% White field to 10-step Stairsteps.

Patterns

There are 10 basic patterns available in the TG-5100 or 19 including the A/B modifier, the following is a list of these and some of their uses.

0. SMPTE Recommend Practice HDTV Colorbars (RP219) is formatted for 16:9 aspect ratio and includes fixed gray levels and a Y-Ramp, as shown below. Also, included with this pattern is a traveling Wizard, which bounces like the ball in the game Pong when it reaches the edge of the raster. This motion is useful for checking for dropped frames as sometimes occurs with video compression schemes or in scaling engine malfunctions. A circle can be added to this pattern to confirm proper aspect ratio.

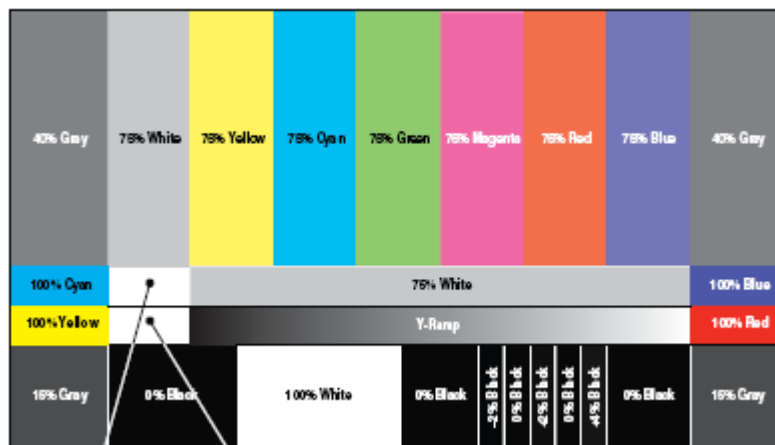

1. Good old 75% colorbars, because it's the de facto standard test pattern in the video transmission world. A circle can be added to this pattern.
2. The moving Zoneplate was designed by the BBC to reveal scaling artifacts. If your monitor native resolution is the same as the selected format there will be just one circle moving like water when a pebble is dropped. The appearances of faint circles outside the center are scaling artifacts – the stronger the appearance and the quantity indicate a poor scaling engine. The A/B switch has no effect on this pattern.
3. 75% Red Flatfield was used in the past to check purity of CRT's – some patterns die hard. The A/B switch changes the flat field to a 5-step Stairstep where both luminance (Y) and chroma (UV) are progressively increasing.
4. 75% Green Flatfield has the same characteristics as the Red.
5. 75% Blue Flatfield has the same characteristics as the Red.
6. White Flatfield is a 75% grayscale. The A/B switch changes this to a 10-step grayscale stairstep pattern.
7. Black Flatfield as the name suggest is luminance (Y) at zero level. The A/B switch changes this to a continuous grayscale ramp. In this ramp there is a black line marker indicating where 100% luminance is reached. The pattern then continues at 100% gray level until the edge of raster.
8. Pathological test pattern. This pattern was designed to check the quality of clock recovery PLL's necessary for decoding SDI data streams. They invented this pattern because it contains data word that can't exist in real world video. It's called pathological for the mental state of engineers whose designs can't pass the test! The A/B switch changes this to a video flash with a tone burst. The audio and video happen precisely at

the same time and people who like to test for audio/video delay (aka lipsync) can use the flash to trigger a scope while monitoring the tone burst and tell exactly what the time relationship between the two.

9. Convergence cross-hatch is a requirement when doing multiple project alignment. It can also be used to converge your old CRT projectors. The A/B switch adds a circle for checking aspect and centering.

Audio Notes

The TG-5100 offers audio channel voice ID's and tones for all 16 stereo channels allotted in the HDSDI specifications. The embedded voice repeats the channel ID every 15 seconds, leaving no doubts or confusion about the audio channel you're monitoring. Plus, between the voice ID's there are standard level 1kHz audio tone for the RIGHT and 440Hz audio tone for the LEFT within each group. The inclusion of standard level tones permits very accurate system leveling and both the US -20dBFS and the European -18dBFS standard levels are supported.

The selection between the US and European levels is a jumper selection and can not be changed without removing the case. After removing the case, locate JP1, and move the suitcase jumper to short pins 2 & 3 for -18dBFS levels.

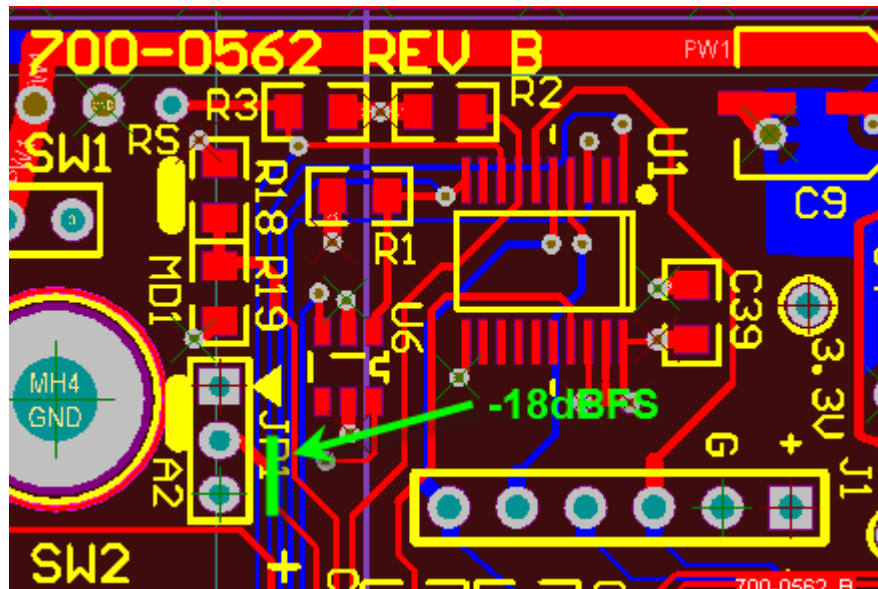

NOTE: The audio is always ON, there are no external means of turning off the voice and tones. That said, the audio is only a tone burst in Pattern 8, Flash mode, there the voice is suppressed.

Battery Option – TG-5100B

The internal Li-Ion battery and its associated charger is a factory installed option only. Field modifications are not possible. Users wanting post sale upgrades must return their units to the factory. The following information applies to the battery models.

- The external power supply both operates unit and charges battery at the same time
- However, the charge time is faster if the unit is turned OFF
- Battery type: Li-Ion, typical run time is 4-5 hours when operated continuously
- Typical battery charge time is 2-3 hours when unit is OFF
- Red LED above POWER switch is ON while charging and turns OFF when charging is complete

- Complete suite of redundant protection circuits are provided to protect against:
 - Over-charge, over-discharge, and charging outside allowable temperatures
- **Power Fail operation:** If AC power fails to the external power supply the unit will automatically change over to battery. For this reason, in bench operation, turn the unit off by its POWER switch at end of work, rather than using the external AC plug strip switch as that will only needlessly discharge the battery

Ordering Information

| | |
|-----------|--|
| TG-5100 | Base model without internal battery |
| TG-5100B* | Base model with internal Li-Ion battery |
| PS-1512 | Ultra Miniature power supply 5VDC, 1A, 100-240VAC, DC plug type EIAJ-2, 1.7mm x 4.0mm. This item is included with all the above models. |

*Please note that battery models are factory order only, non-battery models cannot be field upgraded.

Specifications & Features

- 2 SMPTE 292M compliment outputs
- 10 basic patterns / 19 including A/B modifier
- 10 Video Formats
- Full 20-bit pattern generation
- 16-Channel embedded audio with voicing and tones
- Designed for Portable or Bench applications with lab quality
- Extremely small size - 4 x 2.5 x 1.25 inches
- 100-240VAC to 5V DC power supply included

Patterns A/B:

- RP219 with Motion/+Circle
- Full Field 75% Color bars/+Circle
- Moving Zoneplate
- Red/Stairstep
- Green/Stairstep
- Blue/Stairstep
- White/Stairstep
- Black/Ramp
- Pathological/Sync Flash
- Convergence/+Circle

Formats:

- 720p59.94
- 720p60
- 1080i59.94
- 1080i60
- 1080p29.97
- 1080p24
- 1080sF24
- 1080p25
- 1080sF25
- 1080i25

Warranty

Maxtron warrants this product against defects in materials and workmanship for a period of three years from the date of purchase. In the event of malfunction during the warranty period attributable directly to faulty workmanship and/or materials, Maxtron will, at its option, repair or replace said products or components, to whatever extent it shall deem necessary to restore said product to proper operating condition, provided that it is returned within the warranty period, with proof of purchase and description of malfunction to the address found at our website.

www.maxtronproducts.com

This Limited Warranty does not apply if the fault has been caused by misuse, improper handling, electrical or mechanical abuse, abnormal operating conditions or unauthorized modification to the product.

Units must be returned insured, with shipping charges prepaid. If not insured, shipper assumes the risk of loss or damage during shipment. Returned units must include a description of the problem, as well as the name of the person to contact in case there are any questions.

Maxtron makes no further warranties either expressed or implied with respect to the product and its quality, performance, merchantability, or fitness for any particular use. In no event will Maxtron be liable for direct, indirect, or consequential damages resulting from any defect in this product even if Maxtron has been advised of such damage.

Regulations & Compliance

Maxtron designs follow industry standard methods for minimizing the effects of EMI and RFI interferences as either the source or a victim of such interferences. However, there were no measurements made or required to indicate the degree of compliance to any standard or recommendation. Also, no warranties are made as to the public safety of the design as this product uses a commercially supplied or specified power supplies and PCB materials. No Underwriters Laboratory approvals are suggested or inferred, except for the supplied external power supply.

Basic Disclaimer!

Maxtron reserves the right to change or modify the features or specifications of this product at anytime without notice or the obligation to update or modify previously shipped products. While every effort is made to insure accuracy, Maxtron is not responsible for typographical errors in this document.